

MODEL 201PS AIR PACKER

CONSISTENTLY AND ACCURATELY FILL VALVE BAGS

The Model 201PS Air Filler is a simultaneous fill and weigh packer designed to package products such as sand, concrete, mortar mix or granular minerals that are abrasive into a multi-wall valve bag. The filler is supplied for manual placement of valve bags by an operator and may include, as optional equipment, an automatic bag start switch and/or automatic discharge chair. An optional load cell/flexure scale can be included in the filler frame design to provide input data to a Thompson weight controller which controls all functions of the bag filler.

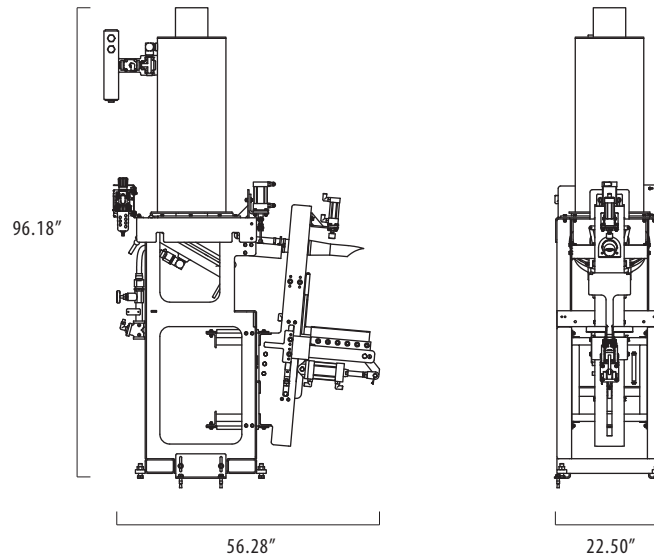

SPECS

Filler Weigh Range:	20 - 110 lbs (10 - 50 kg)
Scale System:	Available in electronic or mechanical weigh system
Filling Rate:	4 - 12 bags/minute (dependent on the weight size and product characteristics)
Weight Accuracy:	Dependent on material type and bag design
Plant Air:	0.5 - 1.5 cu ft of 70 psi clean, dry air is required per cycle (0.042 cu m of 483 kPa)
Shipping Weight:	~800 lbs (363 kg)

BENEFITS

- **Industry Standard for Bag Packers**
- **Most Durable Packers Available**
- **Low Maintenance and Downtime**
- **Consistent and Accurate Bag Filling**
- **Easy to Operate**